

Astrofotografering

... "se det"
ved hjelp av
"se se det"
og andre duppetitter...



Hovedpunkter

- Del 1 "Fra foton til bitt".
 - Fotoelektrisk effekt (ref. Einstein)
 - Halvledereffekter (pn-overganger)
 - Lyssamlingsmaskiner (CCD & CMOS & mm)

Hovedpunkter

- Del 2 ”Duppebitter (Bits and pieces)”
 - Kokebok for hvordan røre sammen sitt eget CCD-kamera
 - Kompaktkamera dyttet nedi okularet (afokalt)
 - ”Dediserte” astrokamera (Prime focus)
 - ”Normale” kamera (DSLR -Prime focus)
 - ”Spesial” kamera” - fullformat++, ultra stort felt
 - ”WEB-kamera” (Sol, måne og planeter)
 - ”Internet-kamera”

Hovedpunkter

- Del 3 ”Det (u)praktiske liv i praksis og teori”
(Utrolig hvor mye som kan gå galt !)
 - Turbulens , ”seeing” og fokusering
 - Fotonbøtte – F-tall og brennvidde
 - Oppstilling, Tracking
 - GoTo med små felt
 - 10 x 5 er ikke alltid lik 1 x 50
 - Bildebehandling CCD-stack/DeepSkyStacker

Fotoelektrisk effekt.

Overgang fra lys til elektroner.

- Visse stoffer frigir elektroner fra valensbåndet ut i ledningsbåndet når de utsettes for lys med relativt kort bølgelengde.
 - Typisk energi gap 1.14 eV i silisium
 - For infrarødt lys benyttes stoffer med lavere energi gap (For eksempel. Germanium 0.55 eV)
- Einstein forklarte dette i 1905 og senere fikk han og Planck Nobelprisen for deres ”forståelse” av lysets natur.

Fotoelektrisk effekt.

Overgang fra lys til elektroner.

- Normalt vil et elektron som er "slått løs" og løftet over energigapet forbli fritt bare i en kort tid før det igjen hopper ned i valensbåndet. Men, **ved å tilføre et elektrisk felt** kan de frie elektronene "vaskes" bort før de rekker å rekombinere.
- Elektronene legges i en **brønn=pixel** etter hvert som de vaskes bort. Samlingen av elektroner kan så etter ønske transporteres til en enhet som måler den elektriske ladningen. Slik har vi muligheten til å telle hvor mange elektroner som er blitt fotoeksitert. Dette blir et mål på **lysintensiteten** i hvert pixel

Fotoelektrisk effekt.

- Lysfølsomheten avhenger av :
 - Pixlenes størrelse dvs. åpningen i ”fotonbøtta”. Dvs omvendt proporsjonalt med ”Megapixelracet”
 - Kvanteeffektiviteten til pixlene sier hvor mange av de innkomne fotoner som faktisk blir registrert. Denne ligger typisk mellom 40% og 90%. Tradisjonell film og menneskets øye har ca. 5%.

Fotoelektrisk effekt.

- Måling av lysintensiteten:
 - Antallet elektroner som er blitt fotoeksitert gir opphav til en analog spenning som A/D omvandles til et digitalt signal med en oppløsning på 8 bitt (feks. JPG file) til 16 bitt (feks. FITS file).
 - Dersom brønnen med elektroner går "full", vil det "renne over" med elektroner og man får "blooming". Anti-blooming kretser kan kompensere for dette, men innfører ulinearitet.

Lyssamlingsmaskin (CCD)

Charge Coupled Device

”Clever Counting Device”

- CCD sensorer har vært foretrukket til astrobruk pga av større følsomhet og mindre støy i forhold til sensorer basert på CMOS teknologi.
- Forskjellen i kvalitet har blitt mindre over tid.
- CMOS har et fortrinn mht lavt strømforbruk og lavere produksjonskostnader.
- CMOS kan sammenlignes med en minnebrikke hvor ”minnet” er antall elektroner som er blitt fotoeksitert.

CCD Analogy

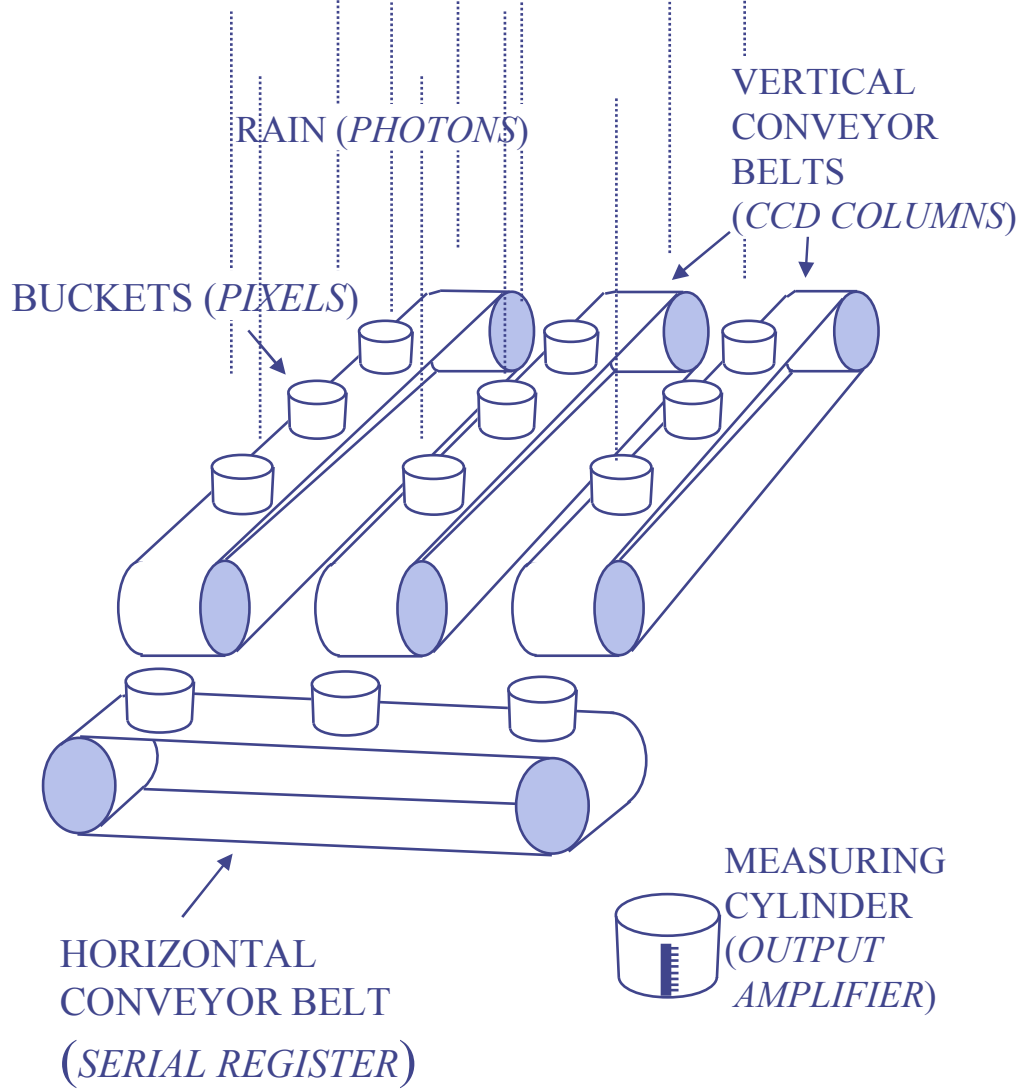

Exposure finished, buckets now contain samples of rain.

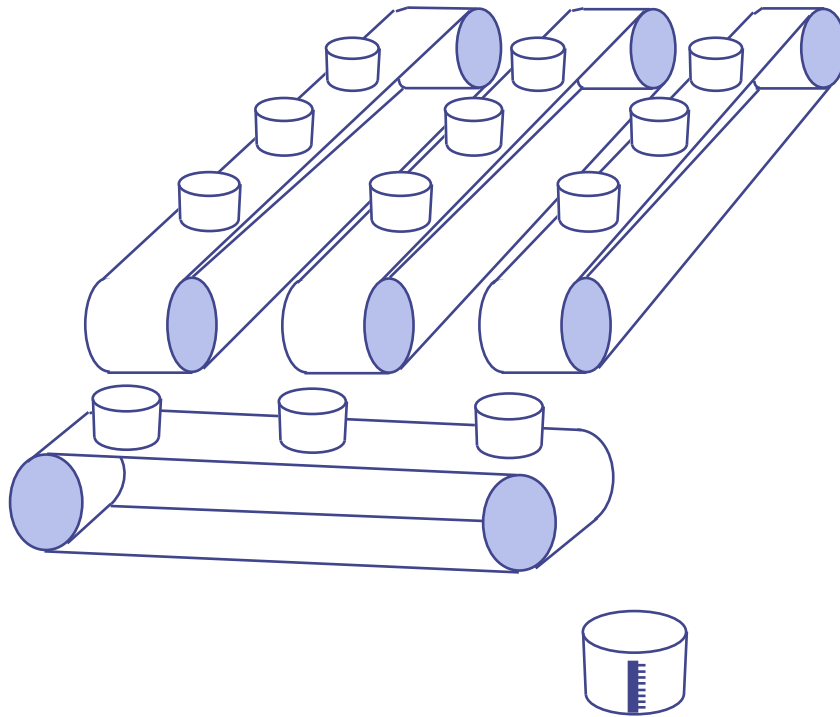

Conveyor belt starts turning and transfers buckets. Rain collected on the vertical conveyor is tipped into buckets on the horizontal conveyor.

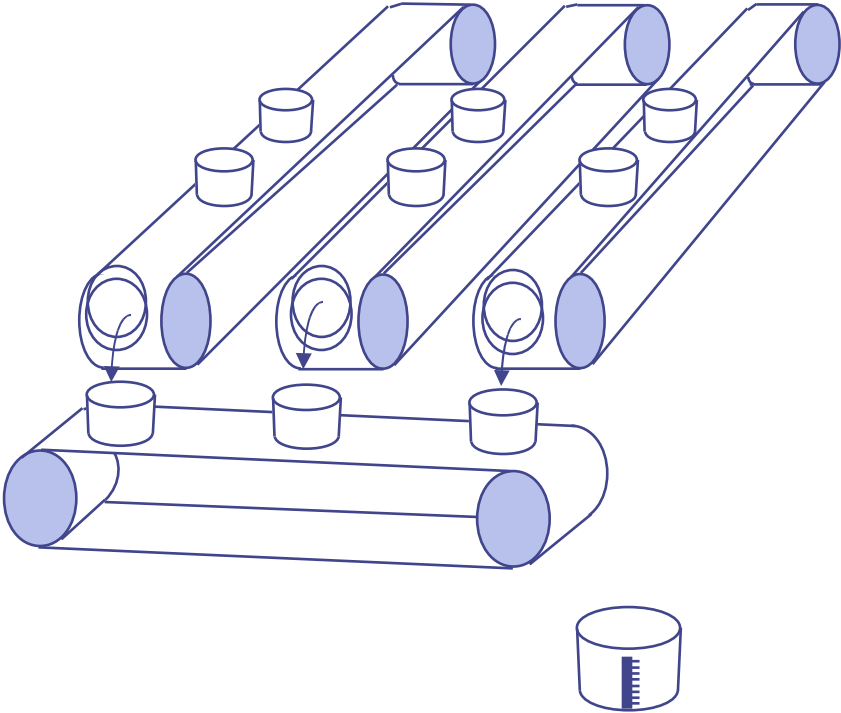

Vertical conveyor stops. Horizontal conveyor starts up and tips each bucket in turn into the measuring cylinder .

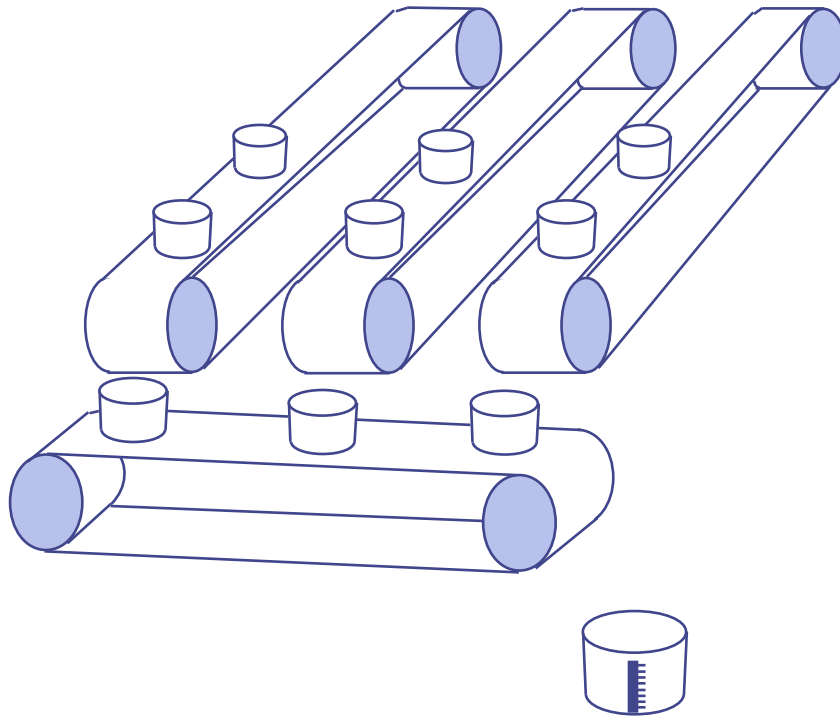

After each bucket has been measured, the measuring cylinder is emptied , ready for the next bucket load.

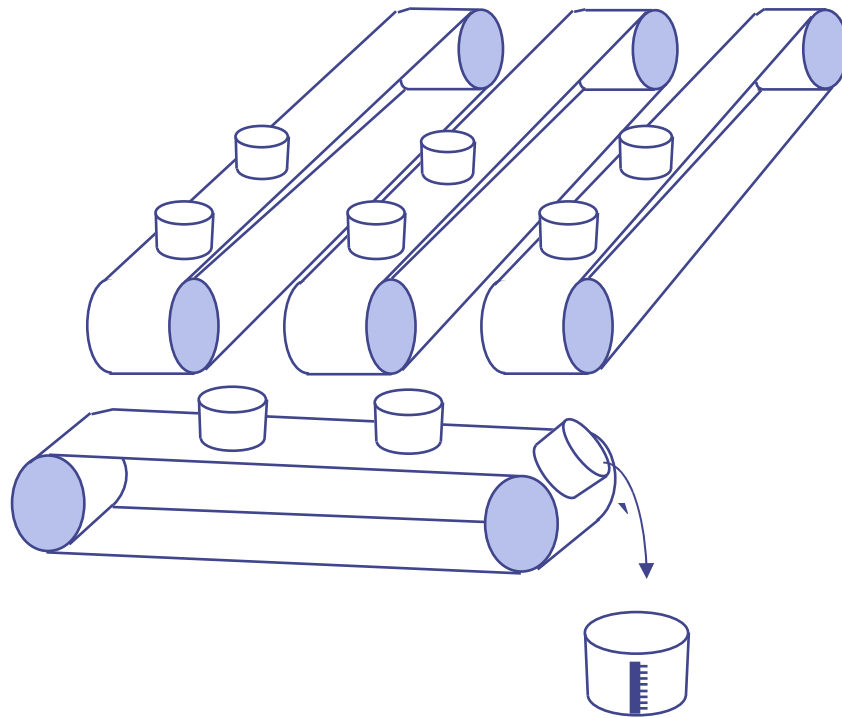

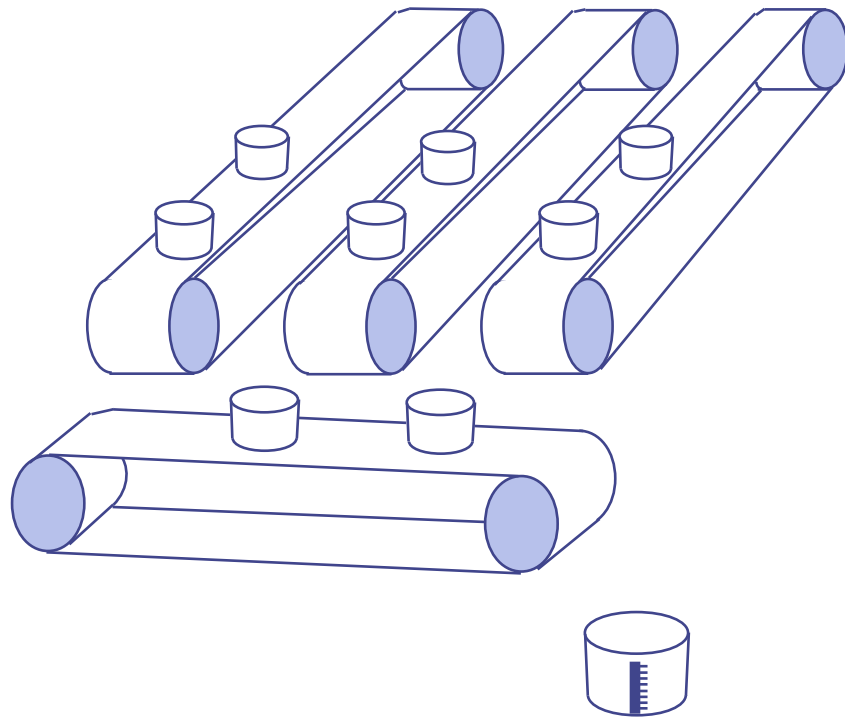

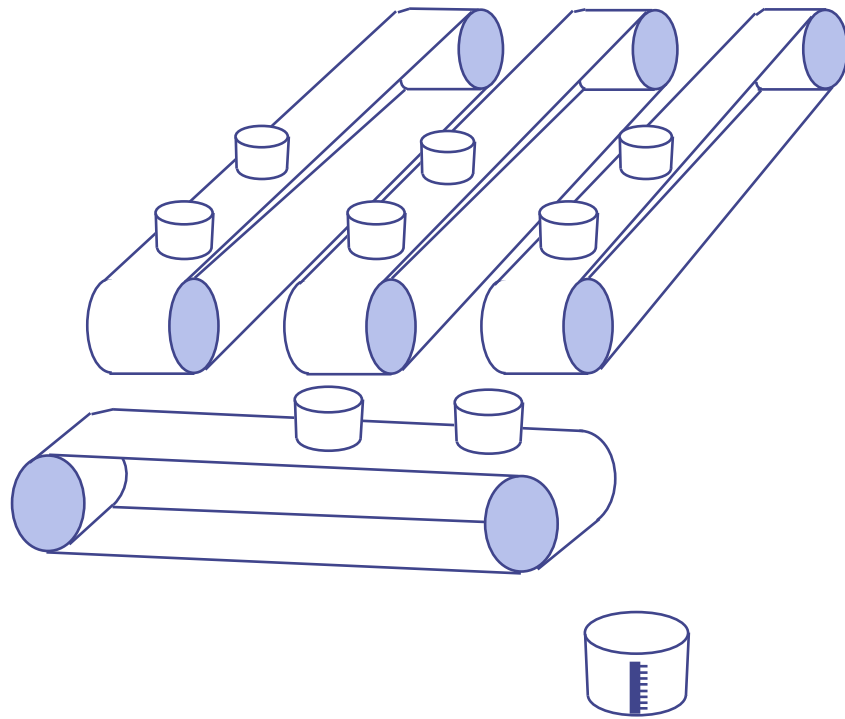

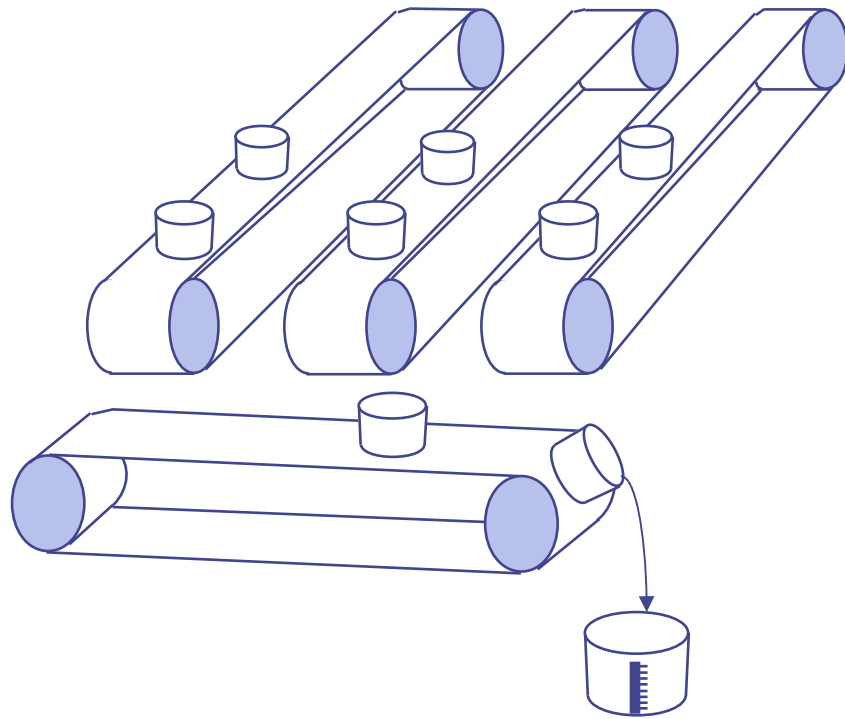

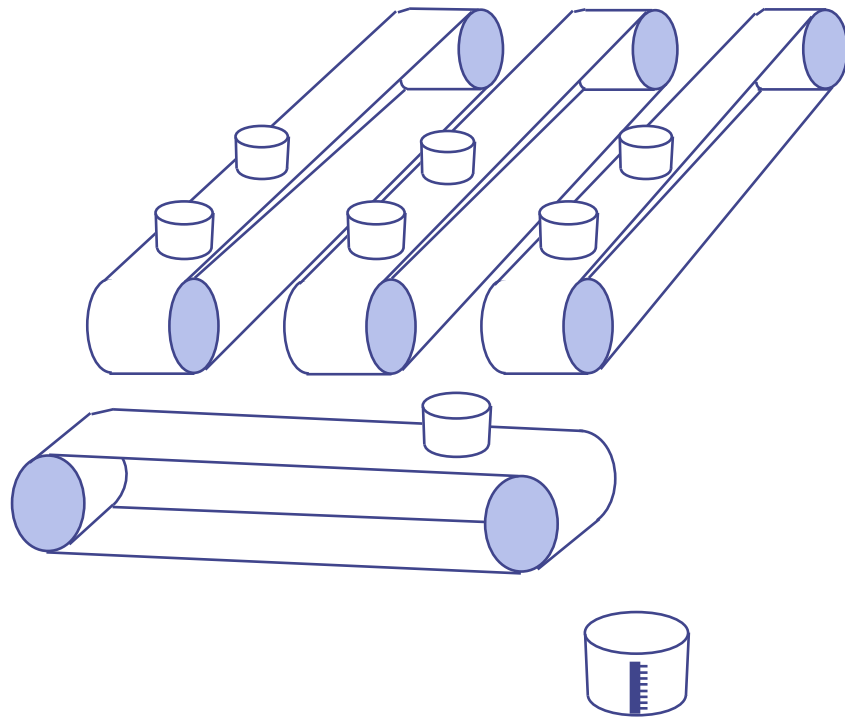

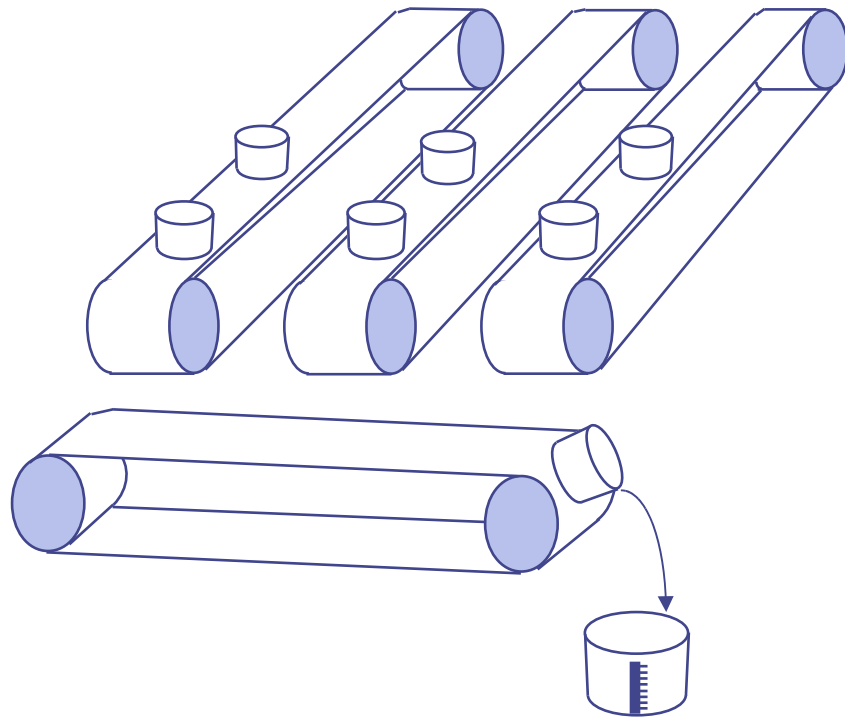

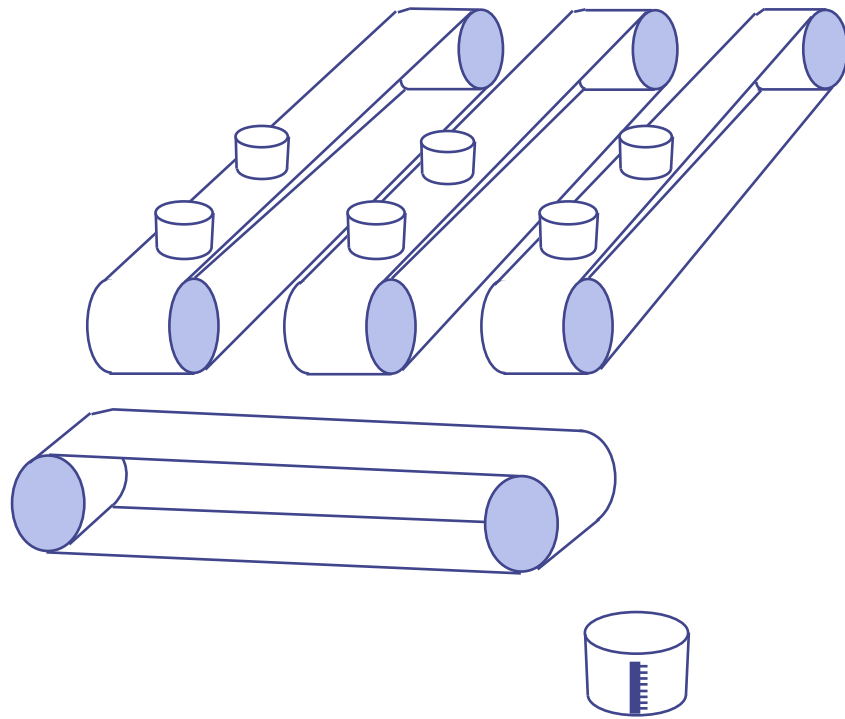

A new set of empty buckets is set up on the horizontal conveyor and the process is repeated.

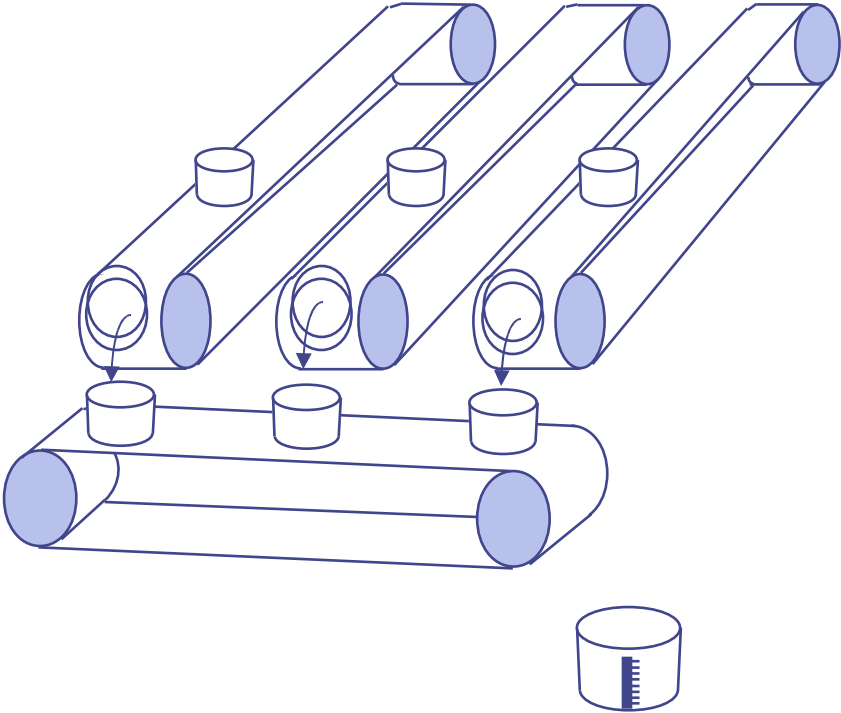

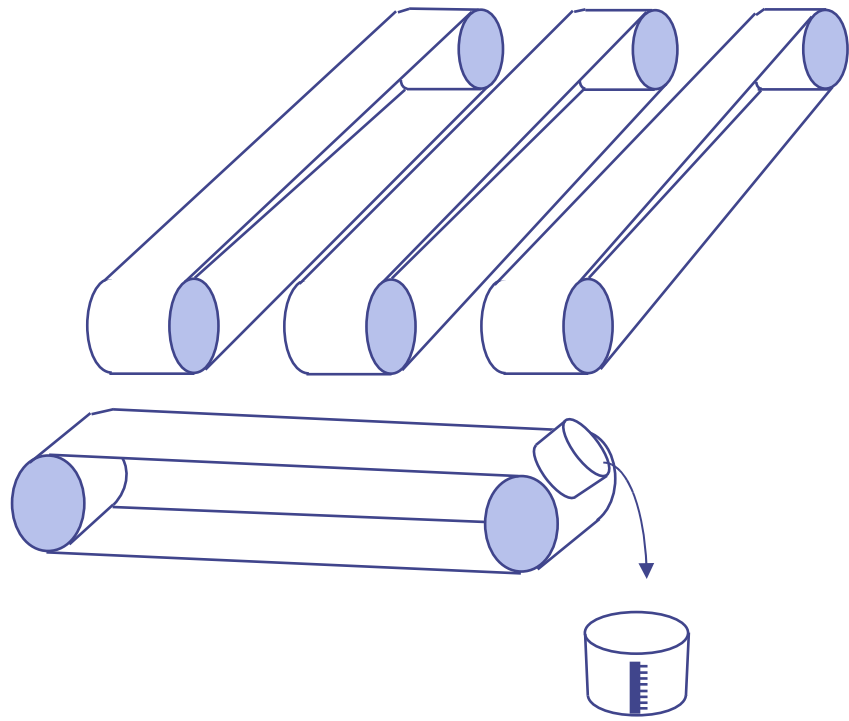

Eventually all the buckets have been measured, the CCD has been read out.

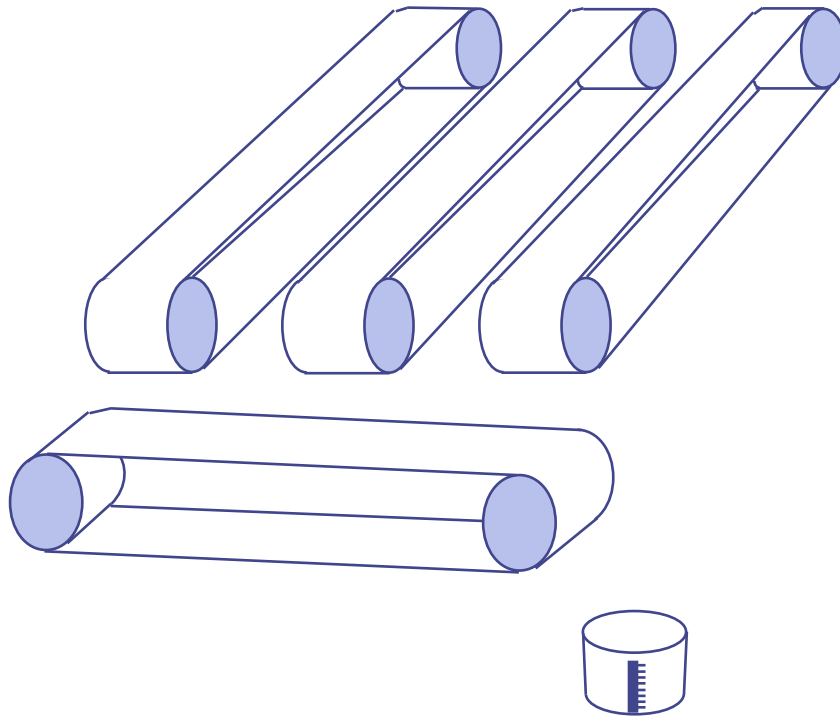

Charge Collection in a CCD.

Photons entering the CCD create electron-hole pairs. The electrons are then attracted towards the most positive potential in the device where they create 'charge packets'. Each packet corresponds to one pixel

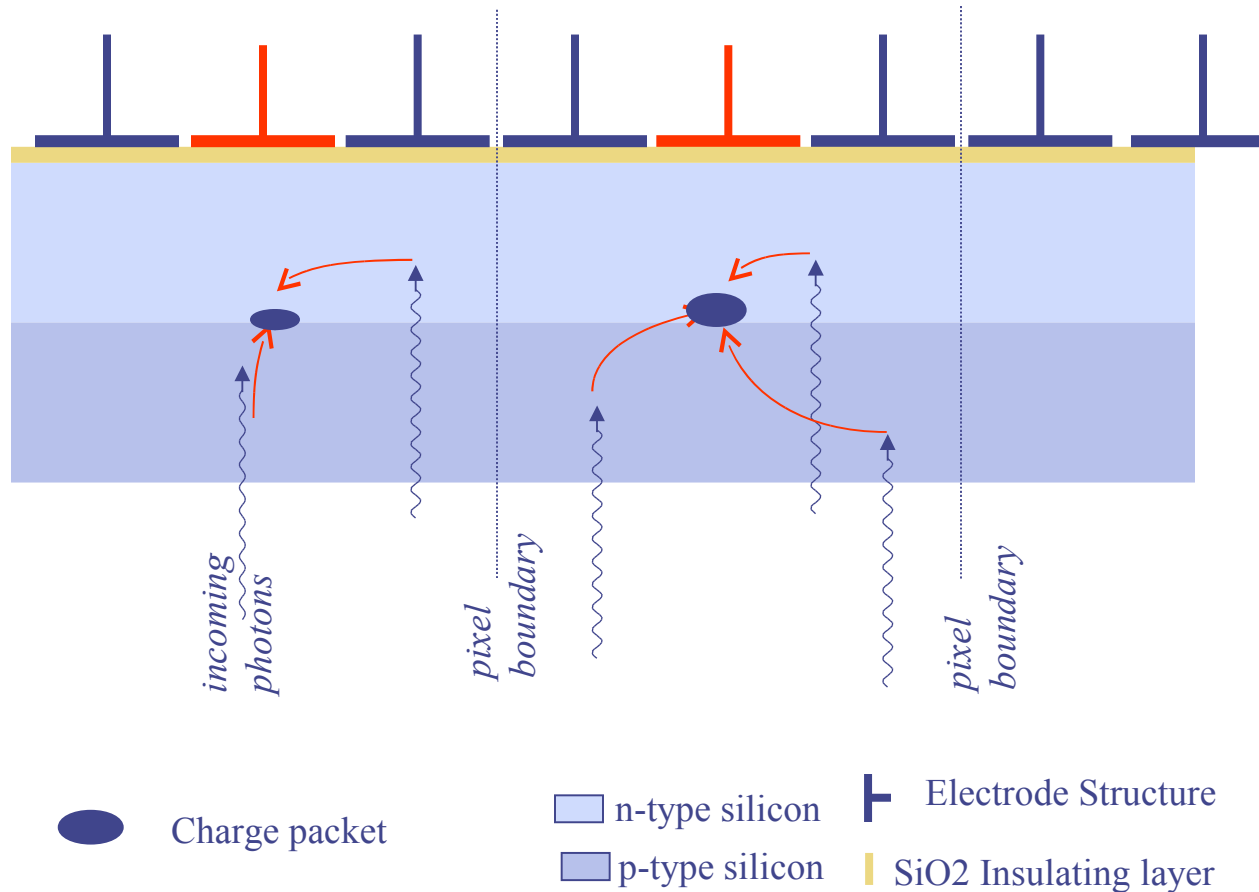

Charge Transfer in a CCD 1.

In the following few slides, the implementation of the 'conveyor belts' as actual electronic structures is explained.

The charge is moved along these conveyor belts by modulating the voltages on the electrodes positioned on the surface of the CCD. In the following illustrations, electrodes colour coded red are held at a positive potential, those coloured black are held at a negative potential.

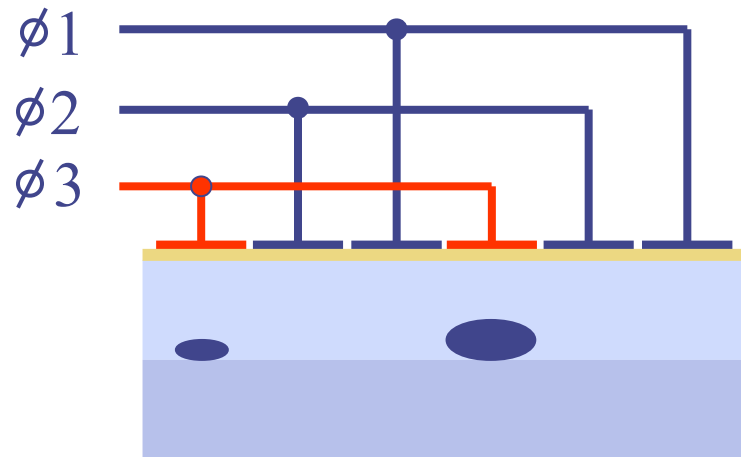

Charge Transfer in a CCD 2.

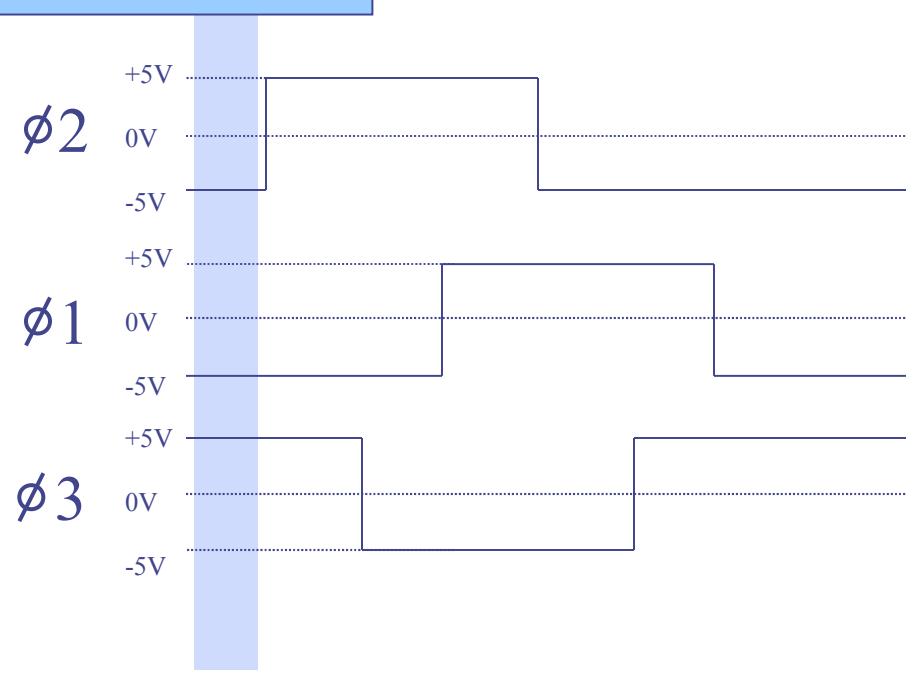
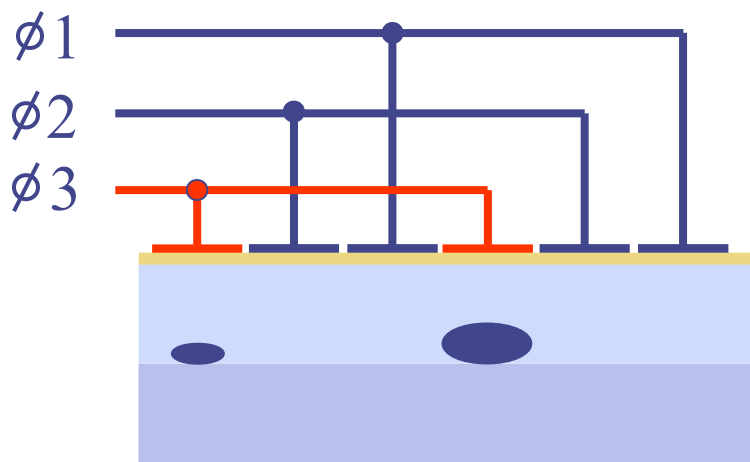

Time-slice shown in diagram

Charge Transfer in a CCD 3.

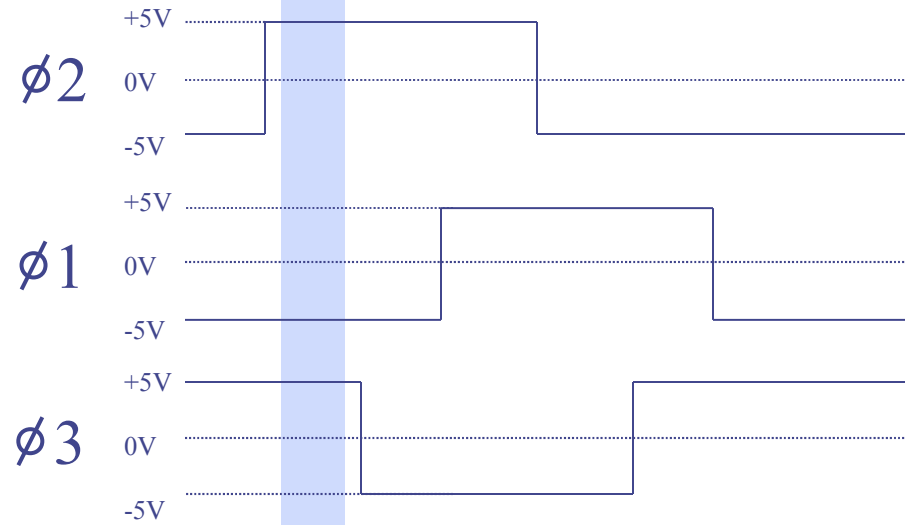
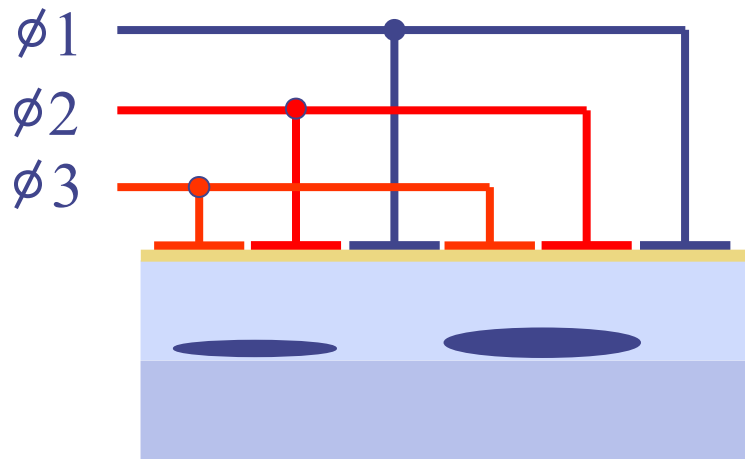

Charge Transfer in a CCD 4.

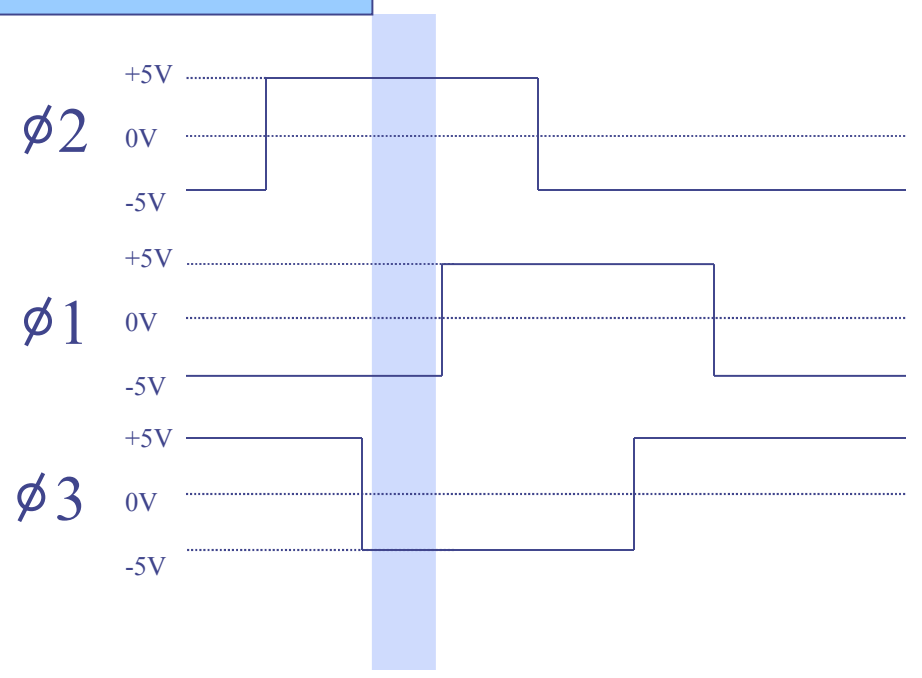
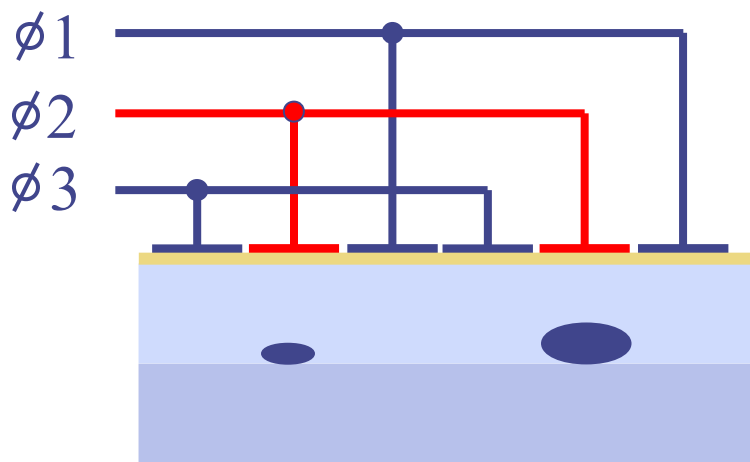

Charge Transfer in a CCD 5.

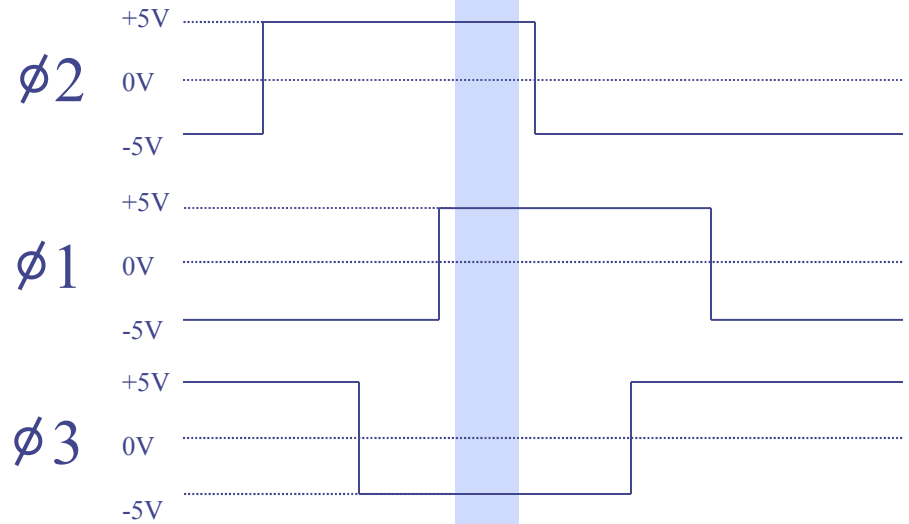
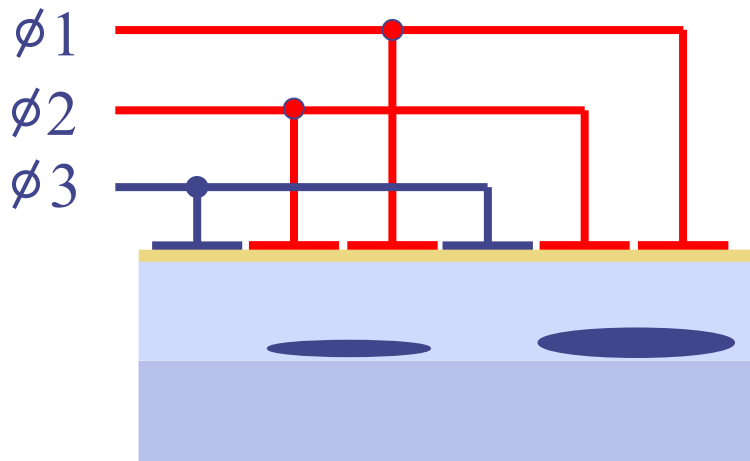

Charge Transfer in a CCD 6.

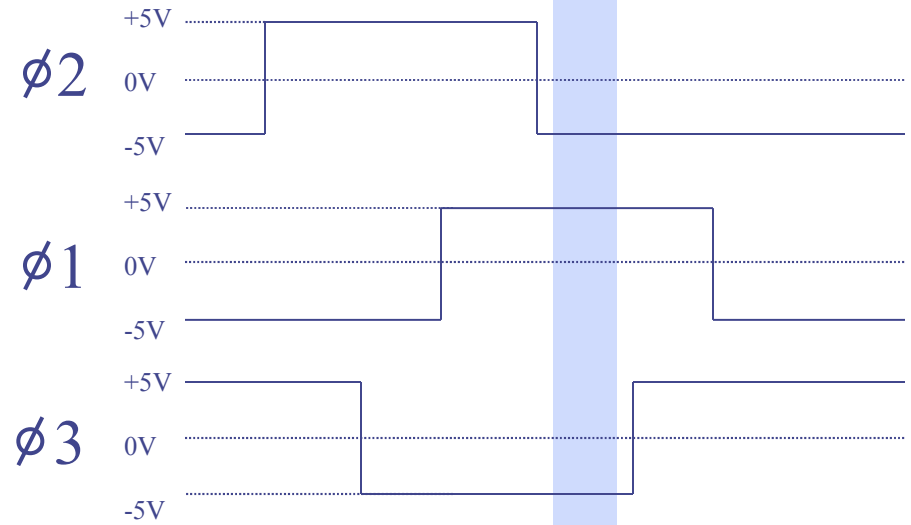
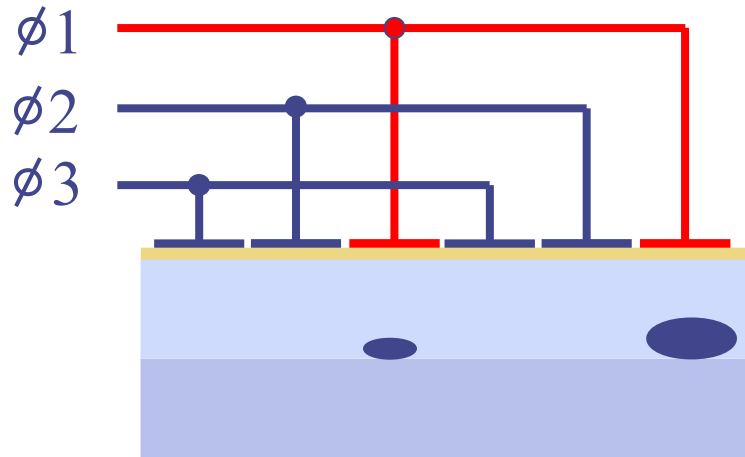

Charge Transfer in a CCD 7.

Charge packet from subsequent pixel enters from left as first pixel exits to the right.

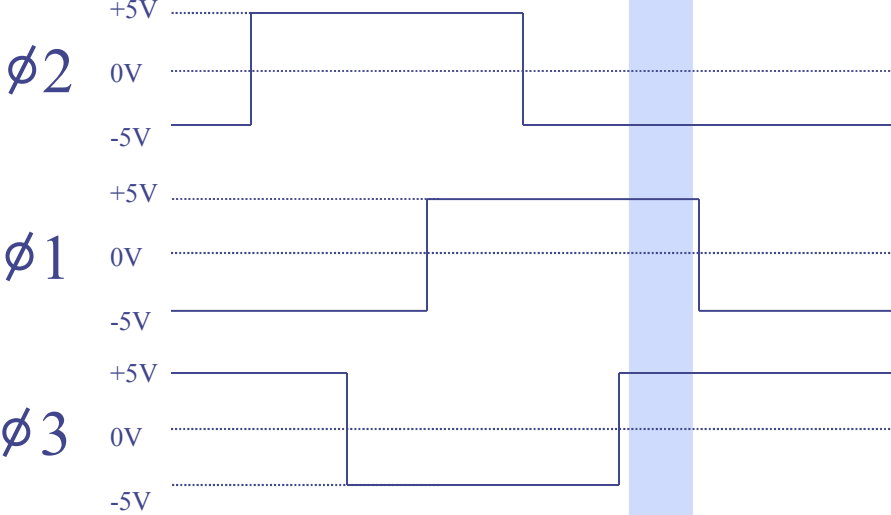
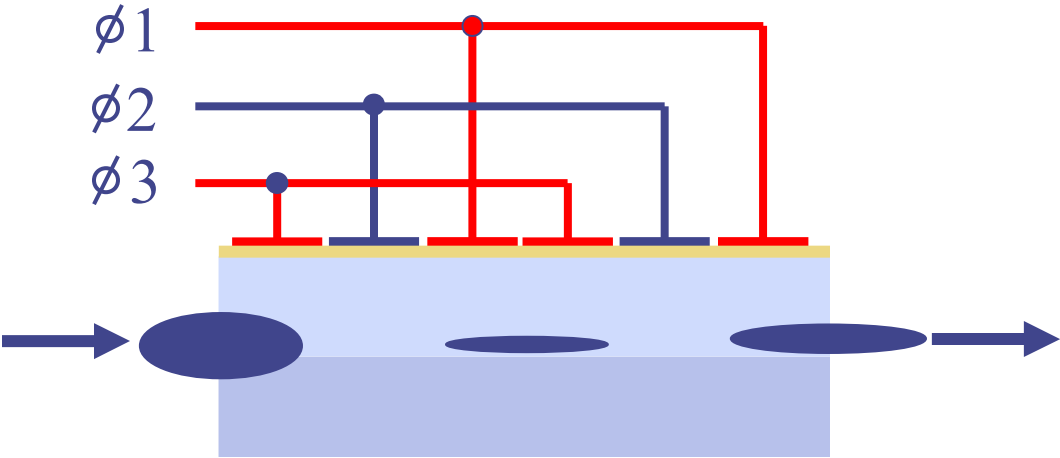

Charge Transfer in a CCD 8.

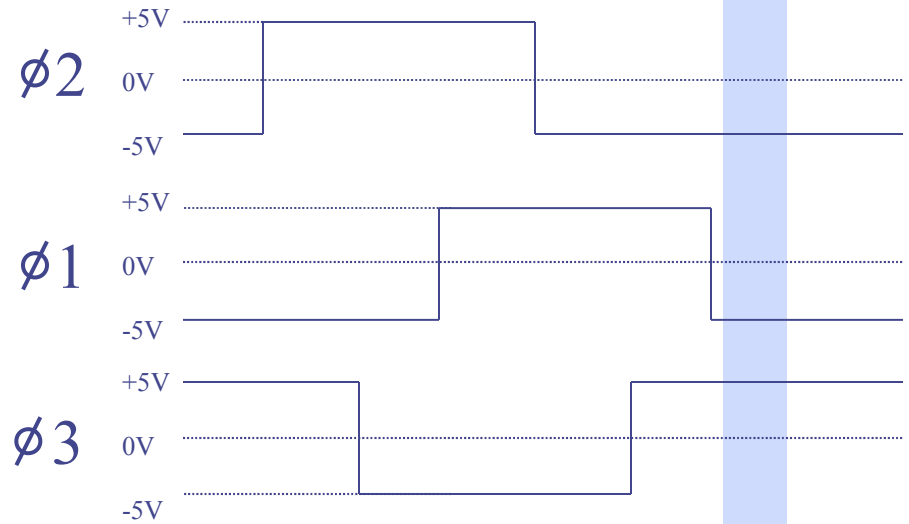
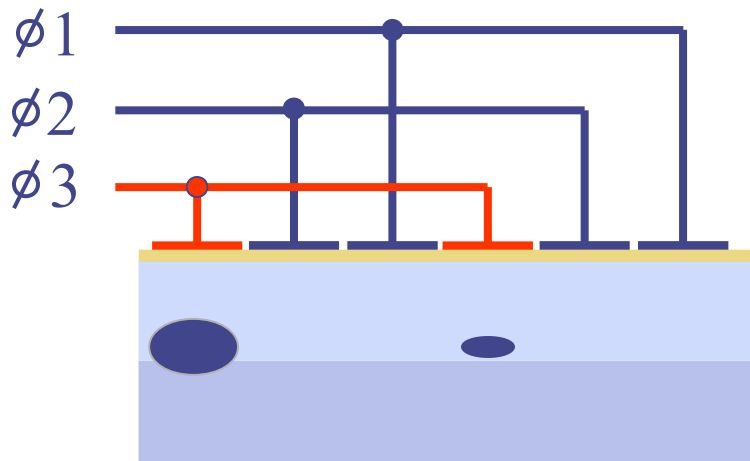

Lyssamlingsmaskin (CMOS)

Complimentary Metal Oxide Semiconductor

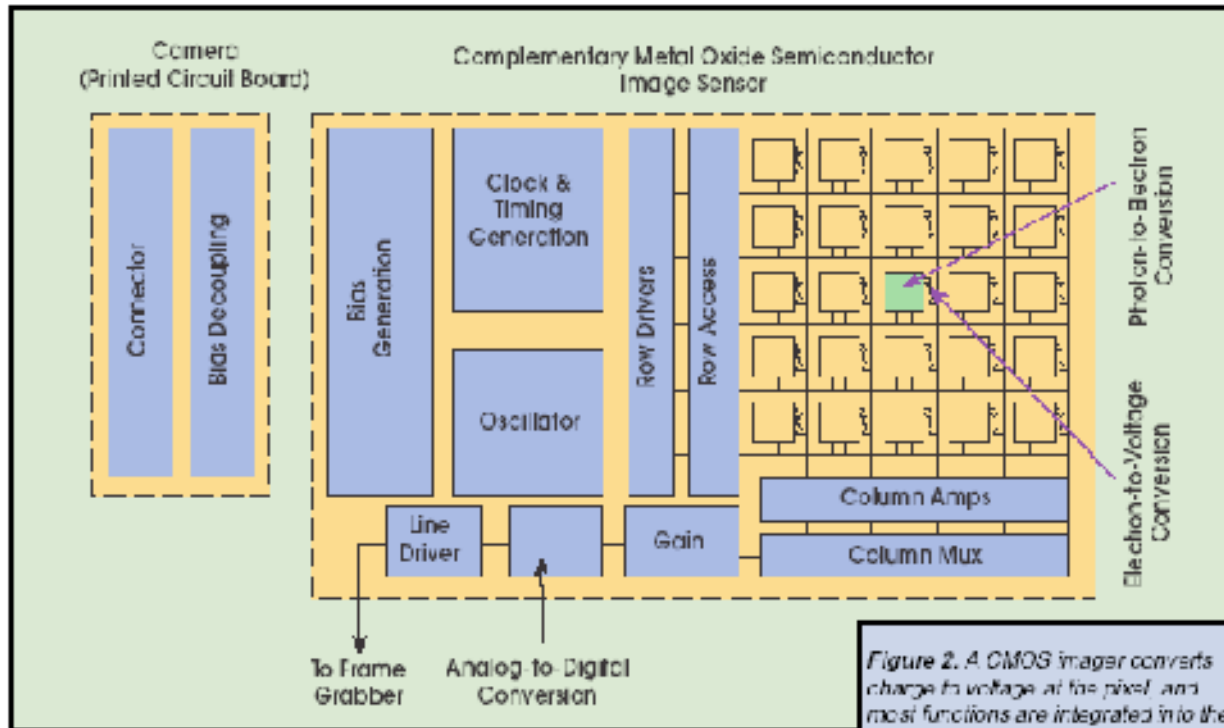

Lyssamlingsmaskin (CMOS)

Oppsummering.

- Transporterer ikke pakker med elektroner - leser av verdien ”der og da”.
- Billigere å lage (Faktor 100)
 - Mer i slekt med all annen halvlederteknologi.
- Bruker lite strøm.(Faktor 100)

Men.....

- Mer støy.
- Mindre antall pixler. (Faktor 4)
- Mindre lysfølsom.
 - Bruker pixelareal til 'logikk'

Hardware versus Humanware

Phototransduction Scheme

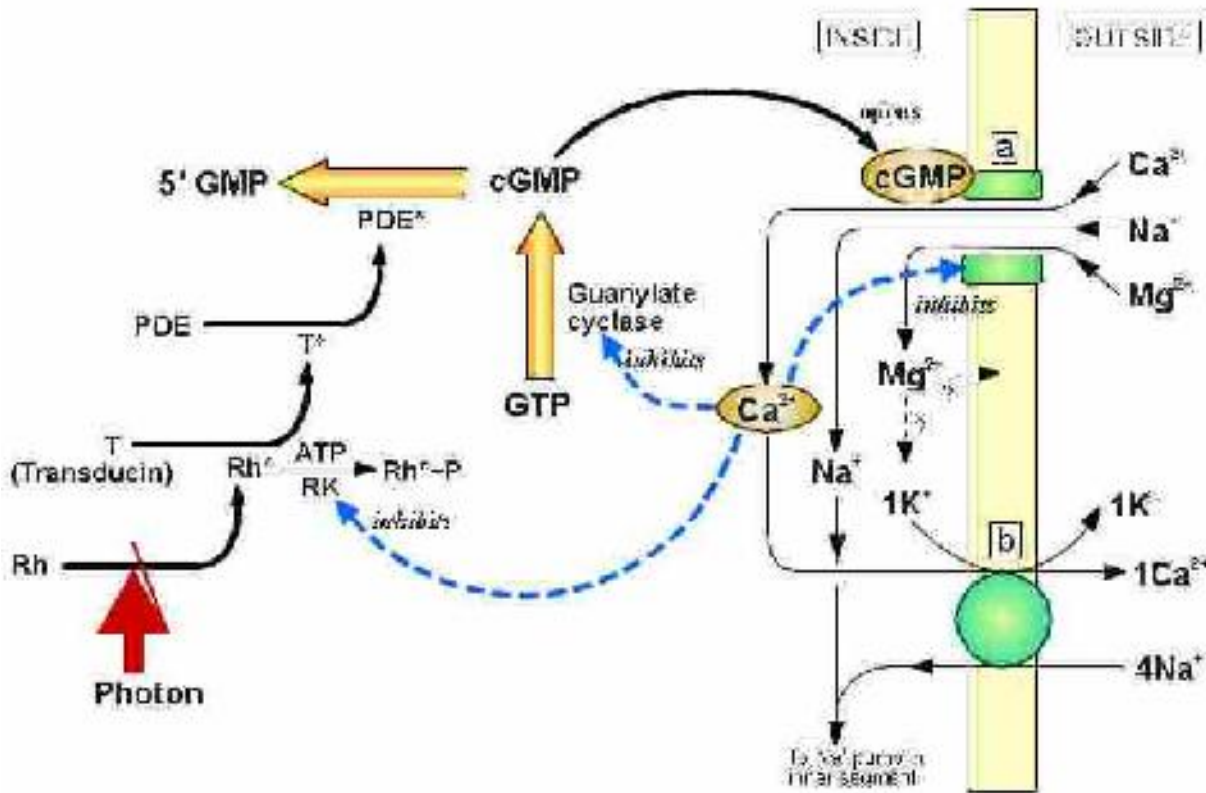

a. cGMP-gated channel, b. $1\text{Ca}^{2+}/\text{Ca}^{2+}/\text{K}^{+}$ exchanger, Rhodopsin, Rh^{*} , activated Rhodopsin, G^{α} , activated G protein, PDE^* , activated phosphodiesterase, PDE , phosphodiesterase, PDE^* , activated phosphodiesterase.

Hardware versus Humanware

The visual cycle is the biological conversion of a photon into an electrical signal in the retina. This process occurs via G-protein coupled receptors called opsins which contain the chromophore 11-cis retinal. 11-cis retinal is covalently linked to the opsin receptor via a Schiff base forming a retinylidene protein. When struck by a photon, 11-cis retinal undergoes photoisomerization to all-trans retinal which changes the conformation of the opsin GPCR leading to signal transduction cascades which causes closure of a cyclic GMP-gated cation channel, and hyperpolarization of the photoreceptor cell.

Following isomerization and release from the opsin protein, all-trans retinal is reduced to all-trans retinol and travels back to the retinal pigment epithelium to be "recharged". It is first esterified by lecithin-retinol acyltransferase (LRAT) and then converted to 11-cis retinol by the isomerohydrolase RPE65. The isomerase activity of RPE65 has been shown, but it is still uncertain whether it also acts as a hydrolase. Finally, it is oxidized to 11-cis retinal before traveling back to the rod outer segment where it can again be conjugated to an opsin to form a new, functional visual pigment (rhodopsin).

Slutt del 1

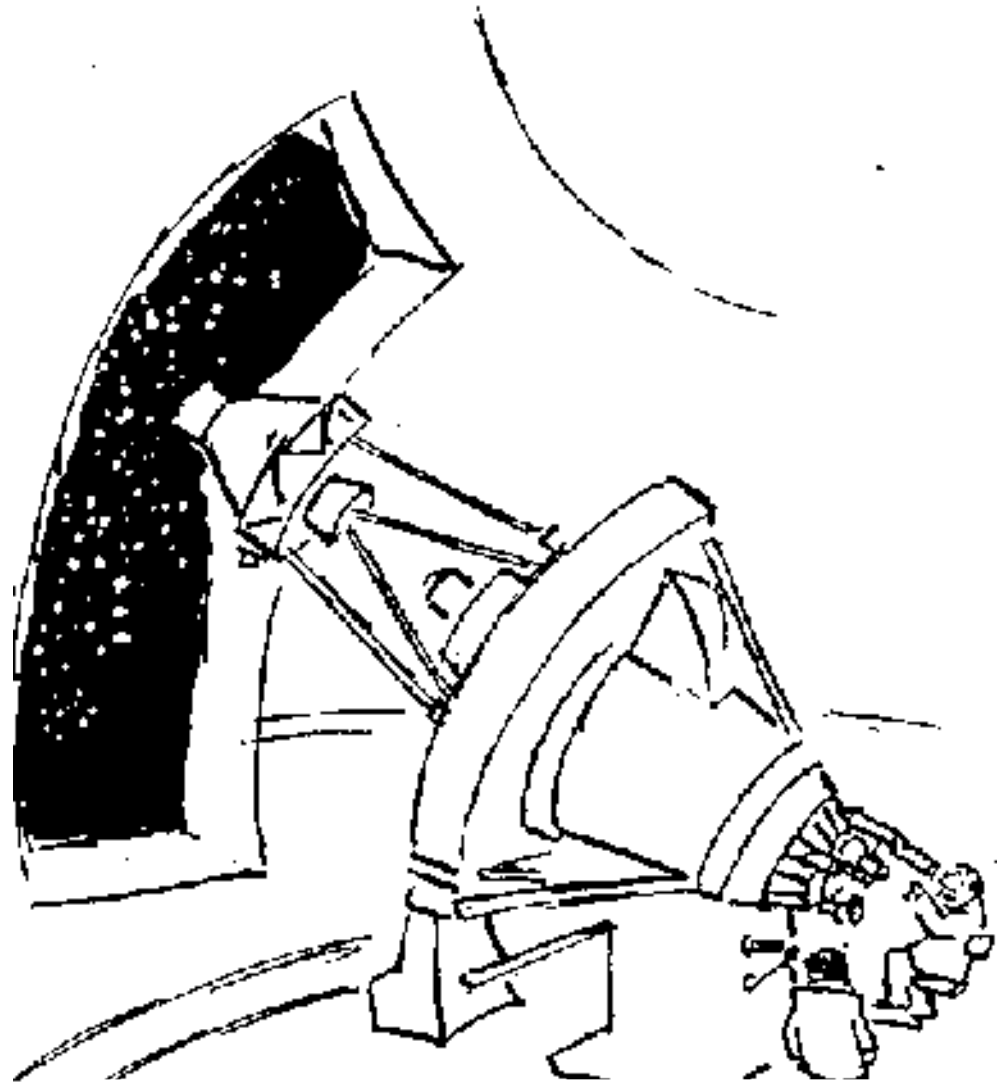

"Actually, they all look alike to me"